

Concrete Pad and Metering Specifications for Three-Phase Service

45 to 1500 KVA Transformers

Inside:

Clearance Requirements Around Pad

Concrete Pad Specifications

Protective Guard Post Specifications

Conduit Specifications

Service Without Connection Cabinet

Service With Connection Cabinet

Location of Pad-Mounted Transformers from Buildings

Metering Requirements

This information is available online at:

www.connexusenergy.com



index

	Page
Clearance Requirements Around Pad	1
Concrete Pad Specifications	2
Protective Guard Post Specifications	2
Conduit Specifications	2-4
Service Without Connection Cabinet	3
Service With Connection Cabinet	4
Location of Pad-Mounted Transformers from Buildings	5-7
Metering Requirements	8-9

Please read this brochure carefully. If there are any questions, call 763.323.2632 or 763.323.2637 or outside the Metro area 1.800.642.1672, ext. 2632 or 2637.

Disclaimer

This brochure is intended to cover only Connexus Energy general requirements applicable throughout the territory of Connexus Energy. It is not intended to be all inclusive of existing policies.

Customer shall provide and install to Connexus Energy specifications:

1. Concrete transformer pad.
2. FOUR protective guard posts.
3. All conduits.
4. Secondary conductors as specified on Figures 3 or 4, whichever is applicable.

Connexus Energy will set transformer when all specifications are met.

FIGURE 1
Clearance Requirements Around Pad

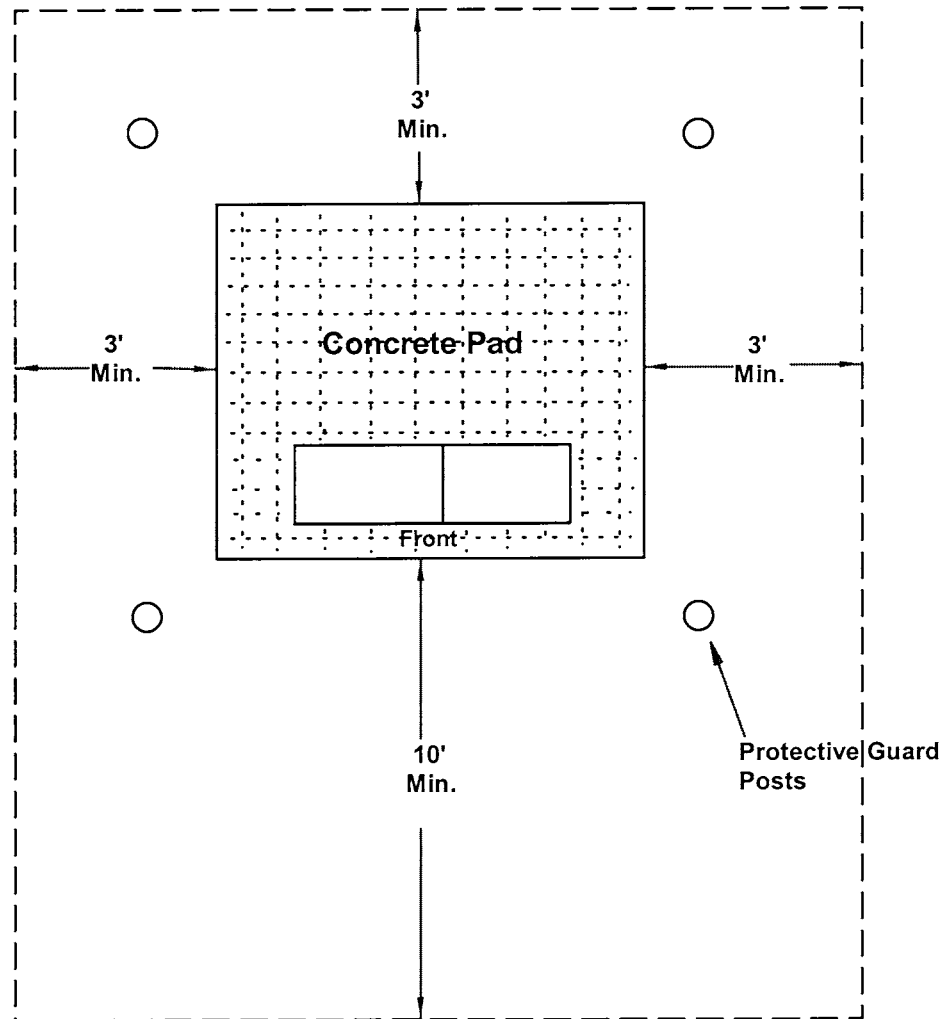

Note: Connexus Energy requires a minimum clearance of 10' in front and 3' on the sides and rear of pad for operation and maintenance of transformer. See section on Location of Pad-Mount Transformers from Buildings.

General sequence for constructing concrete pad, guard posts, and conduits:

1. Determine pad location and orientation (see page 6). Pad location must be in accordance with Connexus Energy clearance requirements (see Figure 1).
2. Level soil under which pad will be placed. Grade must be final.
3. Install the secondary conduits and 90° sweeps as required. All 90° sweeps shall have a minimum radius of 24". Four (4) empty conduits and sweeps installed from connection cabinet to transformer must be **non-metallic**.
4. Level and tamp soil under pad.
5. Frame concrete pad with 2 x 8's, both the sides and cable opening.
6. Install 6 x 6" No. 10 wire mesh.
7. Install FOUR protective guard posts.
8. Pour concrete into 2 x 8' pad frame and into the four 6" steel or PVC protective guard posts.
9. Finish trowel top of pad. Round corners and edges.
10. Remove 2 x 8's from pad after concrete has cured.

FIGURE 2
Transformer Concrete Pad and Protective Guard Post Specifications 45 to 1500 KVA 3PH Transformers

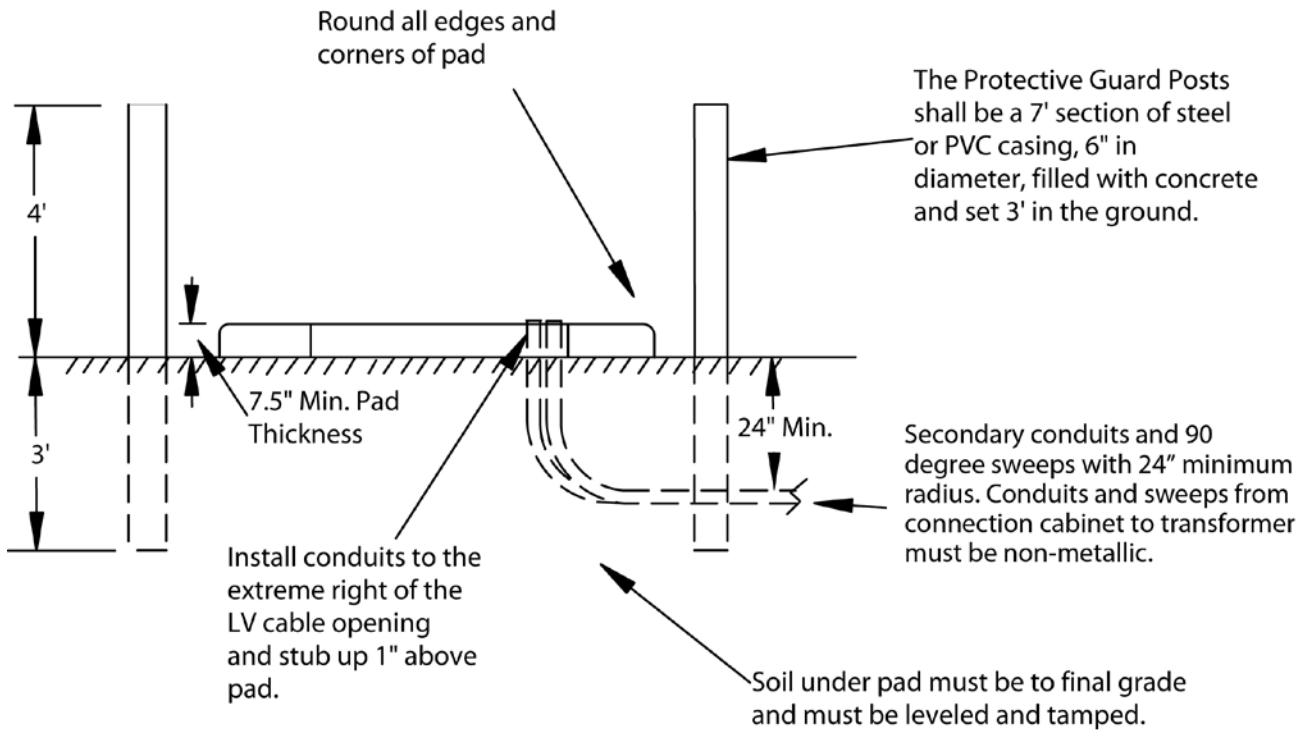
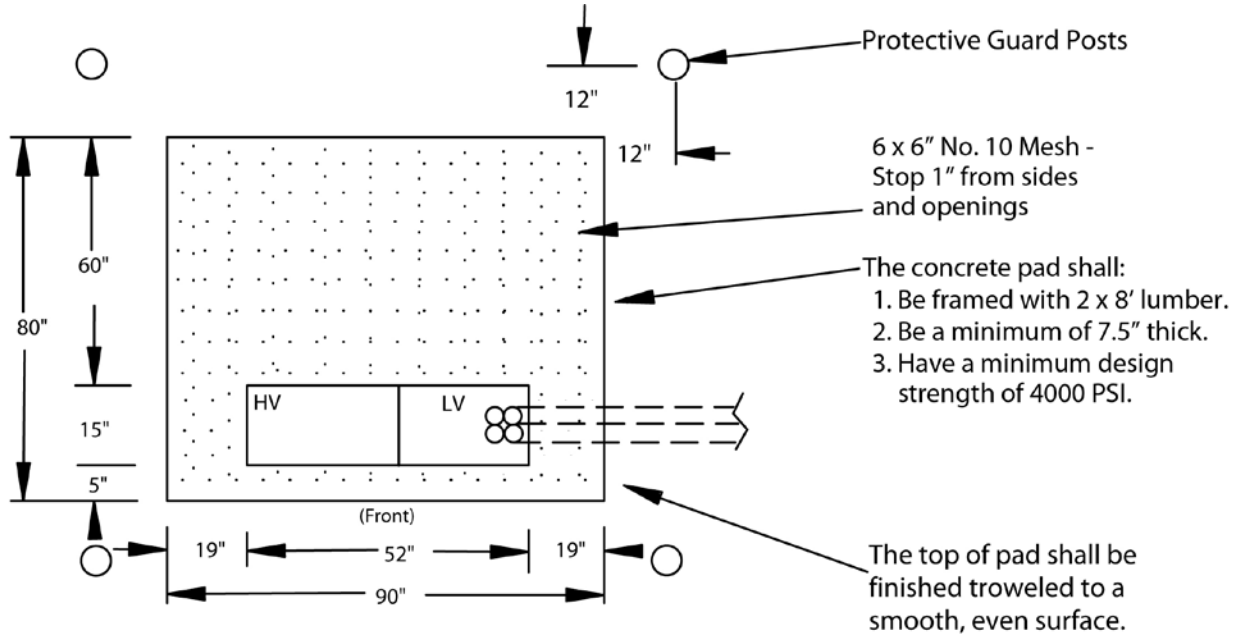

Note: 1. All secondary conduits shall be installed before pad is set or poured.
 2. See "Three-Phase Underground Service With or Without Connection Cabinet" for cable and conduit installation details.

FIGURE 3
Three-Phase Underground Service WITHOUT Connection Cabinet

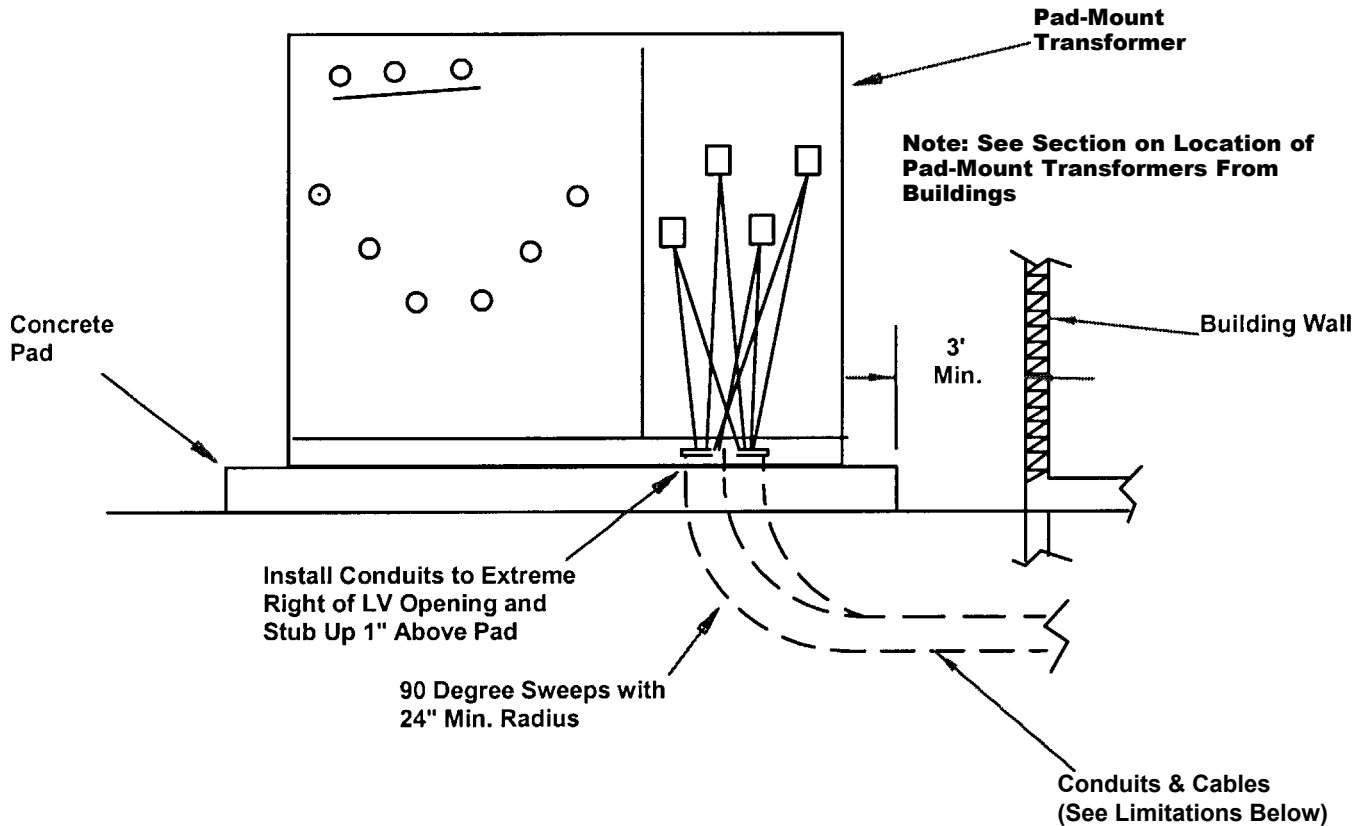

Connexus Energy to provide:

1. Pad-mount transformer, primary conductors, primary terminations, and transformer ground grid.
2. Secondary conductors for services — 200 amp and less — from transformer.
3. Secondary conductor terminations at the transformer.
4. For information on services with nominal voltages greater than 250 volts and service ratings 200 amps or less, see the topic **Voltage Requirements** in the **Electric Meter Requirements** section.

Customer to provide:

1. Concrete transformer pad, guard posts, and conduits. (NOTE: Conduit must be used for secondaries.)
2. Secondary conductors for services greater than 200 amp.
3. Secondary conduits from building to transformer. Install conduits at extreme right of LV side of transformer pad cable opening and a maximum of 1" above the transformer pad.
 Do not terminate conductors on transformer lugs. The number and size of conduits and conductors are limited to:
 - Maximum of four (4) 4-inch conduits
 - Maximum of four (4) conductors per phase
 - Maximum conductor size of 500 kCMIL CU or 750 kCMIL AL

If limitations are exceeded, a connection cabinet is required. See Figure 4 "Three-Phase Underground Service **with** Connection Cabinet" drawing.

FIGURE 4
Three-Phase Underground Service WITH Connection Cabinet

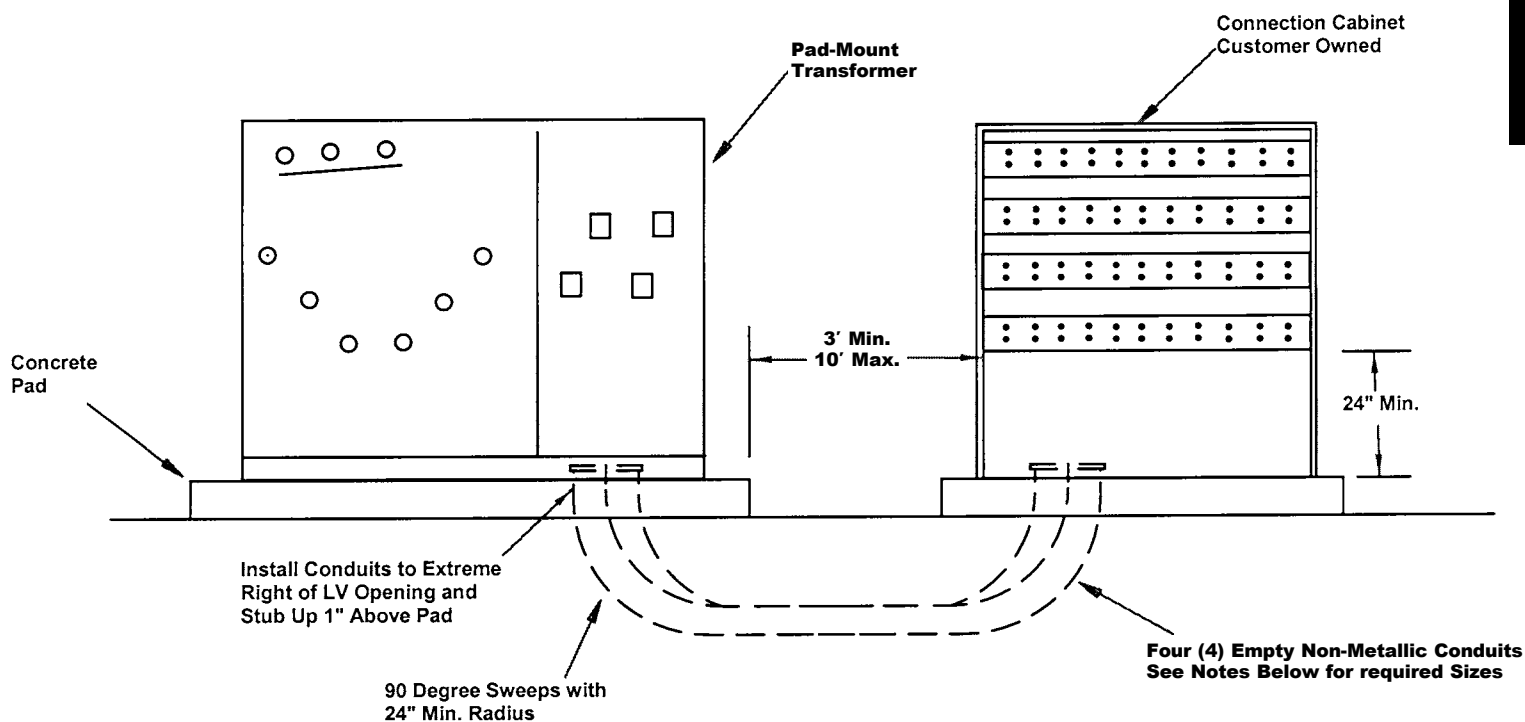

Connexus Energy to provide:

1. Pad-mount transformer, primary conductors, primary terminations, and transformer ground grid.
2. Secondary conductors from the transformer to connection cabinet and secondary terminations at transformer and connection cabinet.

Customer to provide:

1. Concrete transformer pad, guard posts, and conduits.
2. Connection cabinet with all buss-work and concrete pad. The lowest buss-bar in the connection cabinet shall not be less than 24" above the bottom of the cabinet.
3. Four (4) empty conduits from transformer to connection cabinet. The conduits and sweeps must be **non-metallic**. The size and number of conduits required per service are as follows:

Service Size	No. of Conduits	Size of Conduits and Sweeps
200 to 1600 Amp	4	5" non-metallic
2000 to 3000 Amp	4	6" non-metallic
Over 3000 Amp	Contact Connexus Energy	

Install conduits at extreme right of LV side of transformer pad opening and a maximum of 1" above the transformer pad and connection cabinet pad.

Note: Secondary throats from transformer to connection cabinet are not allowed.

4. Secondary conductors, terminations, and conduits from connection cabinet to customer service entrance.

Location of pad-mounted transformers from buildings

I. Non-combustible walls

(Included in this class would be wood-framed, brick-veneered buildings, metal clad, steel-framed buildings; asbestos-cement-board walled; metal-framed buildings; and masonry buildings with a one-hour fire rating.) Pad-mount oil-insulated transformers may be located a minimum distance of 36" from the roof overhang of a non-combustible walled building if all the following clearances are maintained from doors, windows, and other building openings. If a combustible first floor overhang exists, a 10' distance from the edge of the transformer to the edge of the overhang or its associated roof overhang (combination of vertical and horizontal distance) shall be required in addition to the other clearances as shown in Figure 5.

A. Doors Pad-mount oil-insulated transformers shall not be located within a zone extending 20' outward and 10' to either side of a building door used primarily as an entrance or exit for the building, as shown in Figure 6. Doors to electrical equipment rooms are not considered a primary entrance.

B. Building openings Openings shall be defined as both operable and stationary windows and air intake or exhaust vents. Pad-mount oil-insulated transformers shall not be located within a zone extending 10' outward and 10' to either side of an opening located at the level of the transformer, as shown in Figure 7. If the opening is located above the transformer, the distance from the top of the transformer to the opening shall be a minimum of 10'.

The above term "level of the transformer" is to be interpreted as within 10' of the ground.

**FIGURE 5
Non-Combustible Walls**

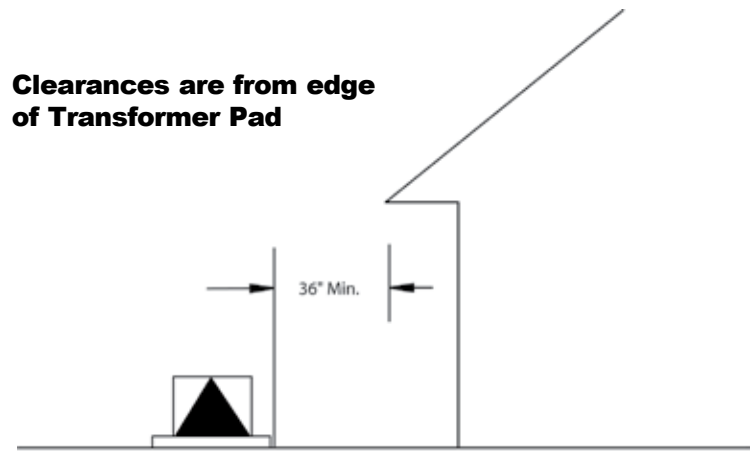

**FIGURE 6
Doors**

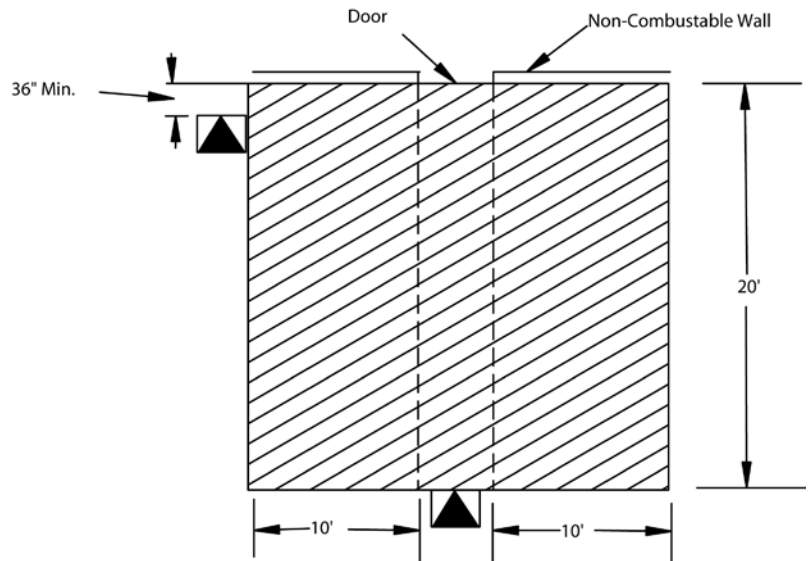

**FIGURE 7
Building Openings**

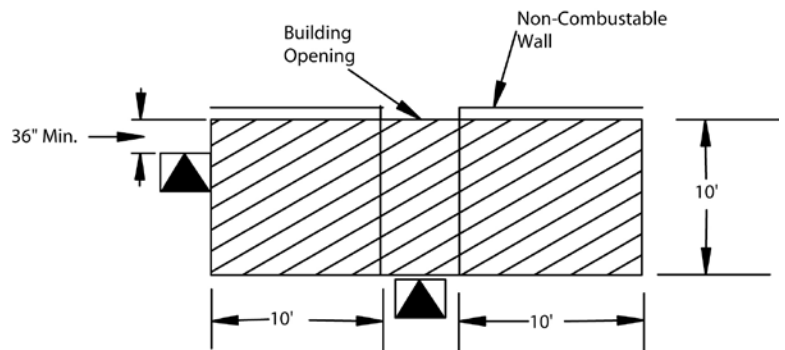

**FIGURES 8 and 9
Combustible Walls**

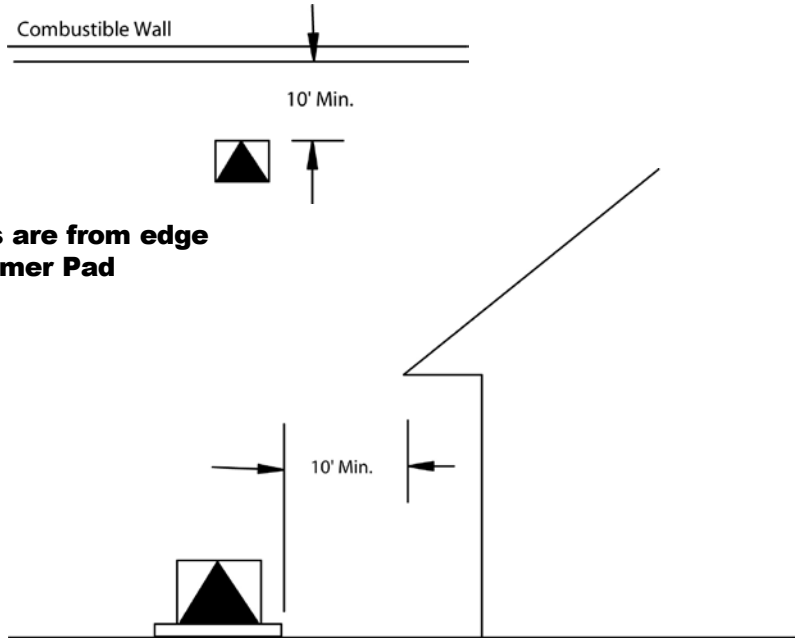

**Clearances are from edge
of Transformer Pad**

II. Combustible walls (Included in this class would be wood buildings and metal clad buildings with wood frame construction.) Pad-mount oil-insulated transformers shall be located a minimum of 10' from the roof overhang of combustible walled buildings if all of the clearances from the building doors, windows, and other openings set forth for non-combustible walled buildings are maintained. If a combustible first floor overhang exists, a 10' distance from the edge of the transformer to the edge of the overhang or its associated roof overhang (combination of vertical and horizontal distance) shall be required in addition to the other clearances as shown in Figures 8 and 9.

III. Barriers (Included in this class are reinforced concrete, brick, or concrete block barrier walls with a three-hour fire rating.) If the clearance in previous section cannot be obtained, a fire-resistant barrier shall be constructed in lieu of the separation. The barrier, when required, is provided by the customer. The following locations are acceptable.

A. Combustible walls The barrier shall extend 36" beyond each side of the pad-mount transformer. The height of the barrier shall be 36" above the top of the pad-mount transformer as shown in Figures 10 and 11. If a combustible first floor overhang exists, the 36" specified shall be measured from the edge of the overhang, or its associated roof overhang, rather than from the main building wall.

**FIGURES 10 and 11
Combustible Walls**

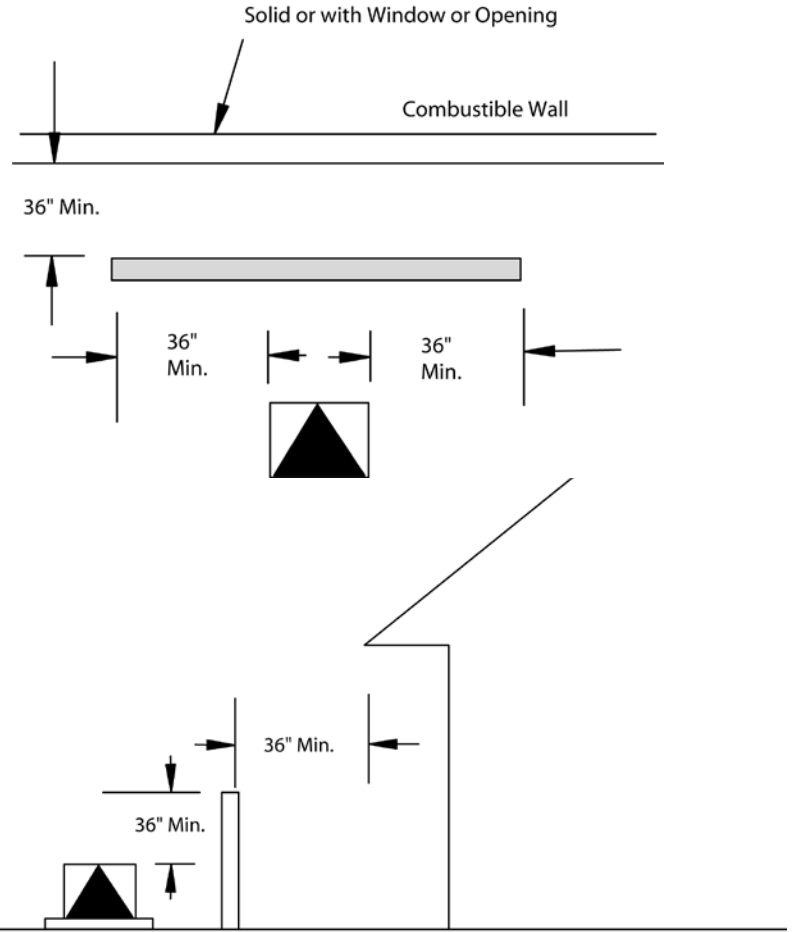

B. Non-combustible walls

The barrier shall extend to a projection line from the corner of the pad-mount transformer to the furthest corner of the window, door, or opening in question as shown in Figures 12 and 13. The height of the barrier shall be 1' above the top of the pad-mount transformer.

IV. Fire escapes Pad-mount oil-insulated transformers shall be located such that a minimum clearance of 20' is maintained from fire escapes at all times.

Exception: Pad-mounted transformers may be located closer to a fire escape than the 20' minimum, when a fire resistant barrier is constructed around the pad-mount transformer (sidewalls and roof). The barrier shall extend a minimum of 1' beyond the pad-mount transformer in all directions. The pad-mount transformer and barrier shall not in any way obstruct the fire escape exit. A clearance of 10' is required in front of the pad-mount transformer doors. Adequate transformer accessibility and ventilation must be provided.

V.

Decorative combustible

enclosure Decorative combustible enclosures (fence) installed by the customer around pad-mounted transformers adjacent to a combustible building wall shall not extend more than 24" beyond the transformer towards the combustible wall. A 10' clearance is required in front of pad-mount transformer doors. Adequate transformer accessibility and ventilation must be provided.

**FIGURES 12 and 13
Non-Combustible Walls**

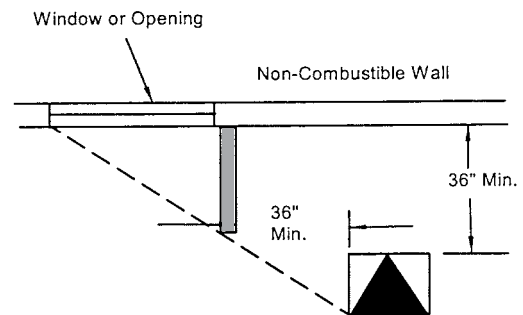
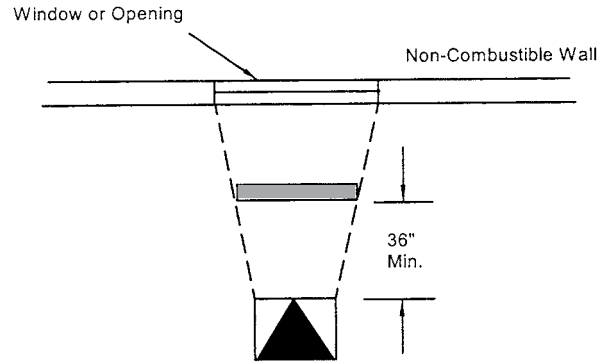

Electric Meter Requirements

Meter Locations

1. All electric meters for new installations and rewires, excluding multi-tenant residential apartment buildings, shall be located on the exterior of the building or the service will not be energized.
 - For multi-tenant residential apartment buildings, Connexus Energy will install a lock box. Property management will provide keys for access to the building and mechanical room where meters are housed. Keys will be placed in the lock box for use by Connexus Energy personnel. When locks are changed, Property management will be required to notify Group Lead Meter Reading at 763.323.2650 to arrange for new keys to be placed in the lock box.
2. All multiple meter socket installations shall have the unit number marked on the face of the meter socket and disconnect.
 - If the meter socket(s) are not clearly and accurately marked, or we are unable to match individual units to the meter socket(s), the building will not be energized until they are properly marked. A new service request must be filed with Connexus Energy at that time.
3. Meters shall not be located where a hazardous condition exists.
4. Meters shall have safe access during normal working hours.
5. If meters are located where there is a potential for falling objects (snow, ice, etc.) to damage the meter, the customer shall provide a protective covering approved by Connexus Energy.
6. Meter sockets shall have an unobstructed space of not less than 4 ft. in front, 1 ft. on both sides and 2 ft. on top.
7. Inside multiple meter socket installations shall have a minimum distance of 2 ft. from the final floor or grade to the center of the lowest meter.
8. Outside multiple meter socket installations shall have a minimum distance of 3 ft. from the final floor or grade to the center of the lowest meter.
9. The maximum distance for inside and outside multiple meter socket installations from the final floor or grade to the center of the highest meter shall be 6 ft. 6 in.
10. If a door is provided on outside multiple meter socket installations, the minimum distance from the final floor or grade to the bottom of the door is 2 ft.
11. All other meter socket installations shall have a minimum distance of 4 ft. and a maximum distance of 6 ft. from the final floor or grade to the center of the meter.

Voltage Requirement

1. Three-phase and single-phase services with voltages 250 volts and below and with service ratings of 200 amps or less will typically use self-contained meters.
2. Three-phase and single-phase services with nominal voltages greater than 250 volts shall have both current transformers (CTs) and voltage transformers (VTs) installed and use transformer-rated meters (see **Transformer-Rated Metering**).
 - The only two exceptions to the VT requirement on service voltages greater than 250 volts are as follows:
 - a. MN/DOT Lighting Service Cabinets L1 & L2 that utilize a cold sequence disconnect wired ahead of the meter. (Any changes to MN/DOT standards regarding cold sequence disconnects must be approved by Connexus Energy.)
 - b. Temporary services 200 amps or less, will not require VTs or cold sequence disconnects. (These must not be in service for a time greater than one year.)
 - Connexus Energy will run the secondary wires from the transformer to the CT cabinet on services with voltages greater than 250 volts and service ratings 200 amps or less, as long as the following conditions are met:
 - a. CT cabinets are installed on the exterior of the structure.
 - b. A service entrance pipe at least 2" in diameter is installed and buried to a depth of 18" from the final grade.

Self-Contained Metering

1. Customers shall provide and install meter sockets on the source side of the customer's service equipment.
2. Meter sockets for three phase up to 200 amps and single phase up to 400 amps (320 amps continuous) require a heavy-duty bypass mechanism. Approved bypass mechanisms are Landis & Gyr (HQ), Milbank (HD200) and Thomas and Betts (TB).
3. All single-phase, self-contained temporary services fed from three-phase transformers shall have a five terminal network meter socket.
4. Single-phase services over 200 amps up to 400 amps shall have a meter socket with a continuous amp rating of 320 amps. If the service will have more than 320 amps continuous, refer to Transformer-Rated Metering.
5. Meter sockets shall be UL approved.

Transformer-Rated Metering

1. Transformer-rated meter sockets shall be furnished by Connexus Energy and installed by the customer for all three-phase services over 200 amps, single phase services over 320 amps continuous, and services with nominal voltages greater than 250 volts (see **Voltage Requirements**). The customer shall provide a minimum of 1¼" conduit from the meter socket to the current transformer cabinet or switchgear, not to exceed 25'. Use 90 degree sweeps and bends in conduit - DO NOT USE LBs.

- If distance from meter socket to the metering point, where CTs are mounted, is between 25-50', the electrical contractor is to run #10 stranded copper wire with the following colors:

Black.....	(Voltage A phase)	Orange	(Current C phase)
White with black stripe or tracer	(Current A phase)	White	(CT current return)
Blue.....	(Voltage B phase)	Green with black stripe or tracer.....	(Socket ground)
Green.....	(Current B phase)	Red with black stripe or tracer	(Meter neutral)
Red	(Voltage C phase)	Will NOT allow all black wires	

If colors are not available, run solid color and mark both ends with black tape OR, use the following colors: Yellow, Brown, or Gray.

- If distance from meter socket to metering point, where CTs are mounted, is over 50', the electrical contractor is to run #8 stranded copper wire.
2. Current transformers (CTs) shall be provided by Connexus Energy and installed by the customer on the source side of the customer's disconnection service equipment inside a cabinet. Voltage transformers (VTs) shall be provided and installed by Connexus Energy inside the customer's CT cabinet.
 3. Current transformer cabinets for services up to 400 amps shall have a minimum size of 30"H x 24"W x 9"D. For services over 400 amps, the current transformer cabinet shall have a minimum size of 48"H x 30"W x 11"D.
 4. Current transformer cabinets or switchgear shall be complete with landing pads.
 5. The door for the current transformer cabinet or compartment shall have provisions for locking with a padlock and shall be hinged on either side.
 6. The meter socket cannot be installed on the door of the current transformer cabinet. It can be mounted on the side if it has a minimum height of 4' and a maximum height of 6' to the center of the meter.
 7. The current transformer cabinet shall have an unobstructed space not less than 2' beyond the door in the open position or a minimum of 5', whichever is greater.
 8. For services requiring a 300KVA or larger transformer, a ½" conduit with an analog telephone line shall be installed to the meter socket. The customer is responsible for terminating/connecting the analog telephone line to a number on the customer's phone equipment. Do not install this conduit into live switchgear. Connexus Energy shall be responsible for connecting the telephone line to the meter.
 9. Call Connexus Energy Engineering Customer Service Specialists at 763.323.2632 or 763.323.2637 and inform them when all the metering equipment is installed and ready to wire.

Restrictions on Metering Installations

1. Connexus Energy will not permit temporary or permanent jumpers to be installed in the meter socket, which will result in unbilled energy.
2. Connexus Energy will not permit meter socket bypass handles to be in the bypass position, which will result in unbilled energy.
3. No customer wiring or devices are permitted on the source side of Connexus Energy's metering points.
4. Meters and all associated metering equipment and cabinets will be sealed and/or locked by Connexus Energy.
5. Unauthorized removal of Connexus Energy's seals and locks is unlawful.
6. Connexus Energy may grant permission to remove a seal and/or lock for maintenance of customer's equipment.
7. Unauthorized removal of Connexus Energy's meter without prior approval from Connexus Energy is unlawful.
8. Contact a Connexus Energy Customer Service Specialist at 763.323.2650 or 1.800.642.1672 for authorization to remove a seal, lock, or meter.

Authorization for Variances

Any variance to these requirements must have prior written authorization from the Connexus Energy Metering Department.

A series of 20 horizontal dotted lines spanning the width of the page, providing a guide for handwriting practice.



14601 Ramsey Boulevard
P.O. Box 279
Ramsey, MN 55303

763.323.2600
1.800.642.1672 outside the Metro area
www.connexusenergy.com
email: info@connexusenergy.com